

CONCRETE SEPTIC TANKS

BOOM CONCRETE septic tanks are designed and built with high quality components including specially formulated concrete, steel rebar, and concrete fiber, which is embedded throughout the tank.

BOOM CONCRETE Wyoming Certified septic tanks come in standard sizes of 1,000 gallons and 1,500 gallons. Septic tanks are kept in stock for immediate delivery.

BOOM CONCRETE will deliver to your site and set the tank in the prepared location.



Septic System Survival

- DO NOT** use a garbage disposal.
- DO NOT** pour grease or oils down the drain.
- DO NOT** flush anything down the drain that is not biodegradable.
 - Disposable Diapers
 - Condoms
 - Feminine Hygiene Products
 - Anything Plastic
 - Etc.
- DO NOT** discharge water softener regeneration to the system.
- DO NOT** use any type of additive in your system. They do not work and can actually cause you problems.
- DO** have your septic tanks pumped every 3-5 years.
- DO** have a second septic tank installed. This will reduce your solid output to your disposal field by approximately 25%.

Tank Warranty

Standard concrete septic tanks should not be more than 48 inches below ground level. If the tank is to be deeper or if any vehicular traffic is expected over the tank, a specially designed tank must be installed. Boom Concrete, Inc. concrete tanks (septic, cistern, or well pit) when installed in accordance with the manufacturer's instructions are warranted against defective materials and/or workmanship for 5 years from date of delivery to the project site. Boom Concrete, Inc. liability is limited to the value of the concrete tank itself and excludes the cost of installation and/or removal.

Boom Concrete, Inc.
220 Girard Ave.
PO Box 437
Newell, SD 57760

Phone: 605-456-2600
800-464-2600
Fax: 605-456-6060
Email: concrete@boomcon.com
Web: www.boomcon.com
January 1, 2018

WYOMING Certified Septic Tanks



- **1,000 Gal. - WY 1 Pc 1 Cmp**
- **1,500 Gal. - WY 1 Pc, 1 Cmp**
- **1,500 Gal. - WY 1 Pc, 2 Cmp**

BOOM
CONCRETE, INC.
Newell, S.D.

Quality Concrete Products



WYOMING CERTIFIED SEPTIC TANKS

- Complete tanks with no assembly.
- Quick and easy setting in the hole.
- Meet or exceed Wyoming State and County Codes.
- Tanks are extra-reinforced.
- Tanks are produced in a climate controlled, indoor plant.
- Each septic tank has 20" openings in the top of the tank to be used for servicing.
- In stock for immediate delivery.

Septic Tank Lid designed with Two Risers, One Cleanout

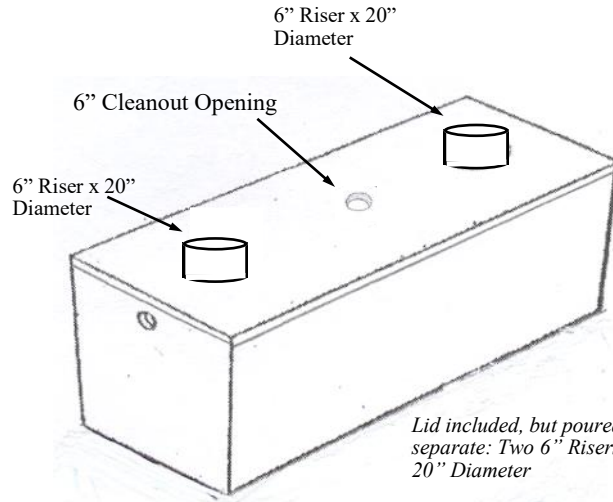

1,500 Gal. WY Two Compartment, One Piece

* Two Compartment System has more bacterial action, serving as treatment for solids, reducing the amount of solids entering the drain field

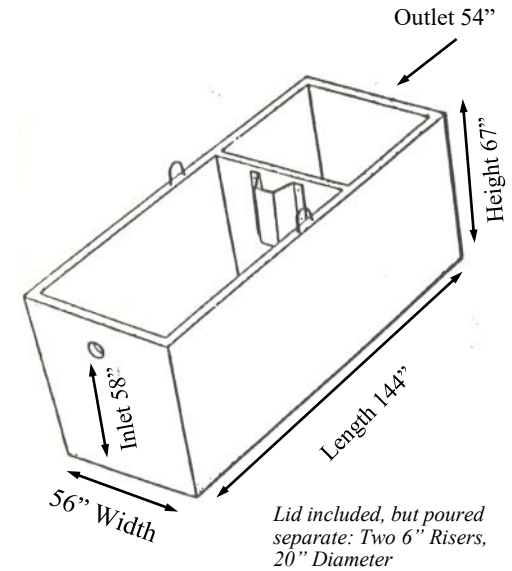

1,500 Gal. WY One Compartment, One Piece

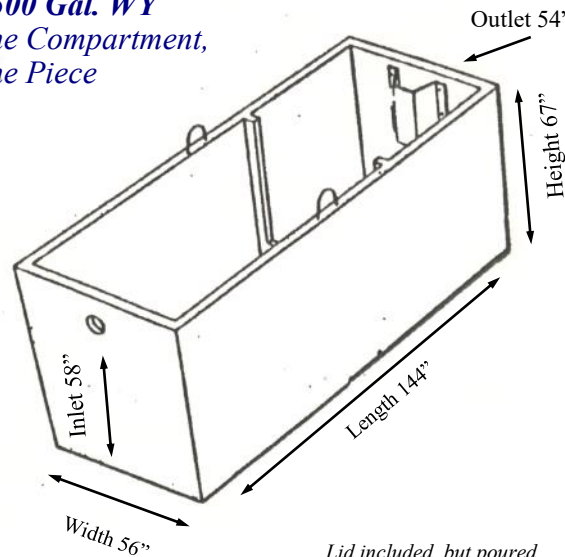

1,000 Gal. WY One Compartment,

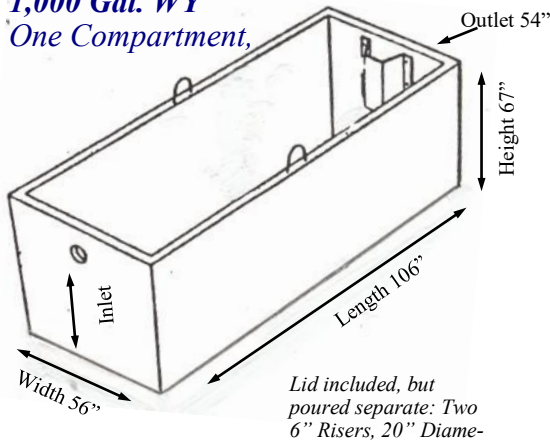

(Septic Tank drawings not to scale. Tank height is figured from bottom of tank to top of lid. Inlet and Outlet is figured from bottom of tank to bottom of inlet or outlet)

Septic-WY	W	L	H	Riser Polylok	Weight
1000 Gal.	56"	106"	67"	6"	4 Ton
1500 Gal.	56"	144"	67"	6"	6 Ton
1500 Gal. 2 cmp	56"	144"	67"	6"	6 Ton